

datavideo

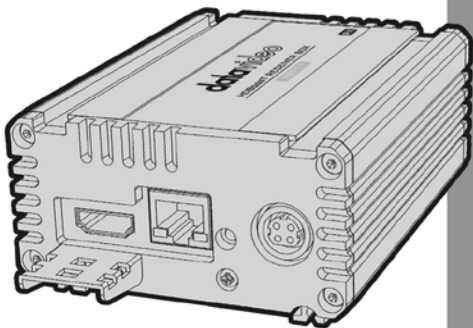

**HDBaseT RECEIVER
BOX
HBT-1 1
Instruction Manual**

www.datavideo.com

Table of Contents

FCC COMPLIANCE STATEMENT	4
WARNINGS AND PRECAUTIONS	4
WARRANTY	6
STANDARD WARRANTY	6
TWO YEAR WARRANTY	6
DISPOSAL	7
1. INTRODUCTION	8
FEATURES	8
2. SYSTEM DIAGRAM	9
3. CONNECTIONS	10
REAR PANEL.....	10
FRONT PANEL.....	11
4. RS-422 CONNECTION	12
5. DIMENSIONS	13
6. SPECIFICATIONS	13
SERVICE AND SUPPORT	15

Disclaimer of Product & Services

The information offered in this instruction manual is intended as a guide only. At all times, Datavideo Technologies will try to give correct, complete and suitable information. However, Datavideo Technologies cannot exclude that some information in this manual, from time to time, may not be correct or may be incomplete. This manual may contain typing errors, omissions or incorrect information. Datavideo Technologies always recommend that you double check the information in this document for accuracy before making any purchase decision or using the product. Datavideo Technologies is not responsible for any omissions or errors, or for any subsequent loss or damage caused by using the information contained within this manual. Further advice on the content of this manual or on the product can be obtained by contacting your local Datavideo Office or dealer.

FCC Compliance Statement

This device complies with part 15 of the FCC rules. Operation is subject to the following two conditions:

- (1) This device may not cause harmful interference, and
- (2) This device must accept any interference received, including interference that may cause undesired operation.

Warnings and Precautions

1. Read all of these warnings and save them for later reference.
2. Follow all warnings and instructions marked on this unit.
3. Unplug this unit from the wall outlet before cleaning. Do not use liquid or aerosol cleaners. Use a damp cloth for cleaning.
4. Do not use this unit in or near water.
5. Do not place this unit on an unstable cart, stand, or table. The unit may fall, causing serious damage.
6. Slots and openings on the cabinet top, back, and bottom are provided for ventilation. To ensure safe and reliable operation of this unit, and to protect it from overheating, do not block or cover these openings. Do not place this unit on a bed, sofa, rug, or similar surface, as the ventilation openings on the bottom of the cabinet will be blocked. This unit should never be placed near or over a heat register or radiator. This unit should not be placed in a built-in installation unless proper ventilation is provided.
7. This product should only be operated from the type of power source indicated on the marking label of the AC adapter. If you are not sure of the type of power available, consult your Datavideo dealer or your local power company.
8. Do not allow anything to rest on the power cord. Do not locate this unit where the power cord will be walked on, rolled over, or otherwise stressed.
9. If an extension cord must be used with this unit, make sure that the total of the ampere ratings on the products plugged into the extension cord do not exceed the extension cord rating.

10. Make sure that the total amperes of all the units that are plugged into a single wall outlet do not exceed 15 amperes.
11. Never push objects of any kind into this unit through the cabinet ventilation slots, as they may touch dangerous voltage points or short out parts that could result in risk of fire or electric shock. Never spill liquid of any kind onto or into this unit.
12. Except as specifically explained elsewhere in this manual, do not attempt to service this product yourself. Opening or removing covers that are marked "Do Not Remove" may expose you to dangerous voltage points or other risks, and will void your warranty. Refer all service issues to qualified service personnel.
13. Unplug this product from the wall outlet and refer to qualified service personnel under the following conditions:
 - a. When the power cord is damaged or frayed;
 - b. When liquid has spilled into the unit;
 - c. When the product has been exposed to rain or water;
 - d. When the product does not operate normally under normal operating conditions. Adjust only those controls that are covered by the operating instructions in this manual; improper adjustment of other controls may result in damage to the unit and may often require extensive work by a qualified technician to restore the unit to normal operation;
 - e. When the product has been dropped or the cabinet has been damaged;
 - f. When the product exhibits a distinct change in performance, indicating a need for service.

Warranty

Standard Warranty

- Datavideo equipment is guaranteed against any manufacturing defects for one year from the date of purchase.
- The original purchase invoice or other documentary evidence should be supplied at the time of any request for repair under warranty.
- Damage caused by accident, misuse, unauthorized repairs, sand, grit or water is not covered by this warranty.
- All mail or transportation costs including insurance are at the expense of the owner.
- All other claims of any nature are not covered.
- Cables & batteries are not covered under warranty.
- Warranty only valid within the country or region of purchase.
- Your statutory rights are not affected.

Two Year Warranty

- All Datavideo products purchased after 01-Oct.-2008 qualify for a free one year extension to the standard Warranty, providing the product is registered with Datavideo within 30 days of purchase. For information on how to register please visit www.datavideo.com or contact your local Datavideo office or authorized Distributors
- Certain parts with limited lifetime expectancy such as LCD Panels, DVD Drives, Hard Drives are only covered for the first 10,000 hours, or 1 year (whichever comes first).

Any second year warranty claims must be made to your local Datavideo office or one of its authorized Distributors before the extended warranty expires.

Disposal



For EU Customers only - WEEE Marking

This symbol on the product indicates that it will not be treated as household waste. It must be handed over to the applicable take back scheme for the recycling of Waste Electrical and Electronic Equipment. For more detailed information about

the recycling of this product, please contact your local Datavideo office.

1. Introduction

The HBT-10 and HBT-11 are respectively the HDBaseT transmitter and receiver with a maximum allowable transmission distance of 100 meters. The transmitter allows transmission of up to 4K image quality video.

With the 48V power connected to one end of the HBT-11 HDBaseT receiver, the HBT-11 will thus be able to power the transmitter by Power over Ethernet (PoE). On the transmitter end (HBT-10), there is also a 12V/30W DC output serving to supply power to backend devices.

DVIP control can be achieved by one Ethernet cable connecting between the transmitter and the receiver. In other words, HDMI video, DVIP control signals and Power over Ethernet (PoE) can be transmitted between the transmitter and the receiver on just one Ethernet cable.

Features

- Transmit up to 4Kx2K video from HBT-10 Transmitter Box to HBT-11 Receiver Box.
- Extend video transmission up to 100m from HBT-10 Transmitter Box to HBT-11 Receiver Box.
- Transmit video, audio, DVIP Ethernet control, RS-422/232 and PoE by a single Cat.5e/6/6a/7 cable
- 48V PoE Power supply from HBT-11 Receiver side.
- 12V 30W DC output at HBT-10 Transmitter Box side.
- Supports DVIP Control Protocol
- Supports RS-422/232 Control Protocol

2. System Diagram

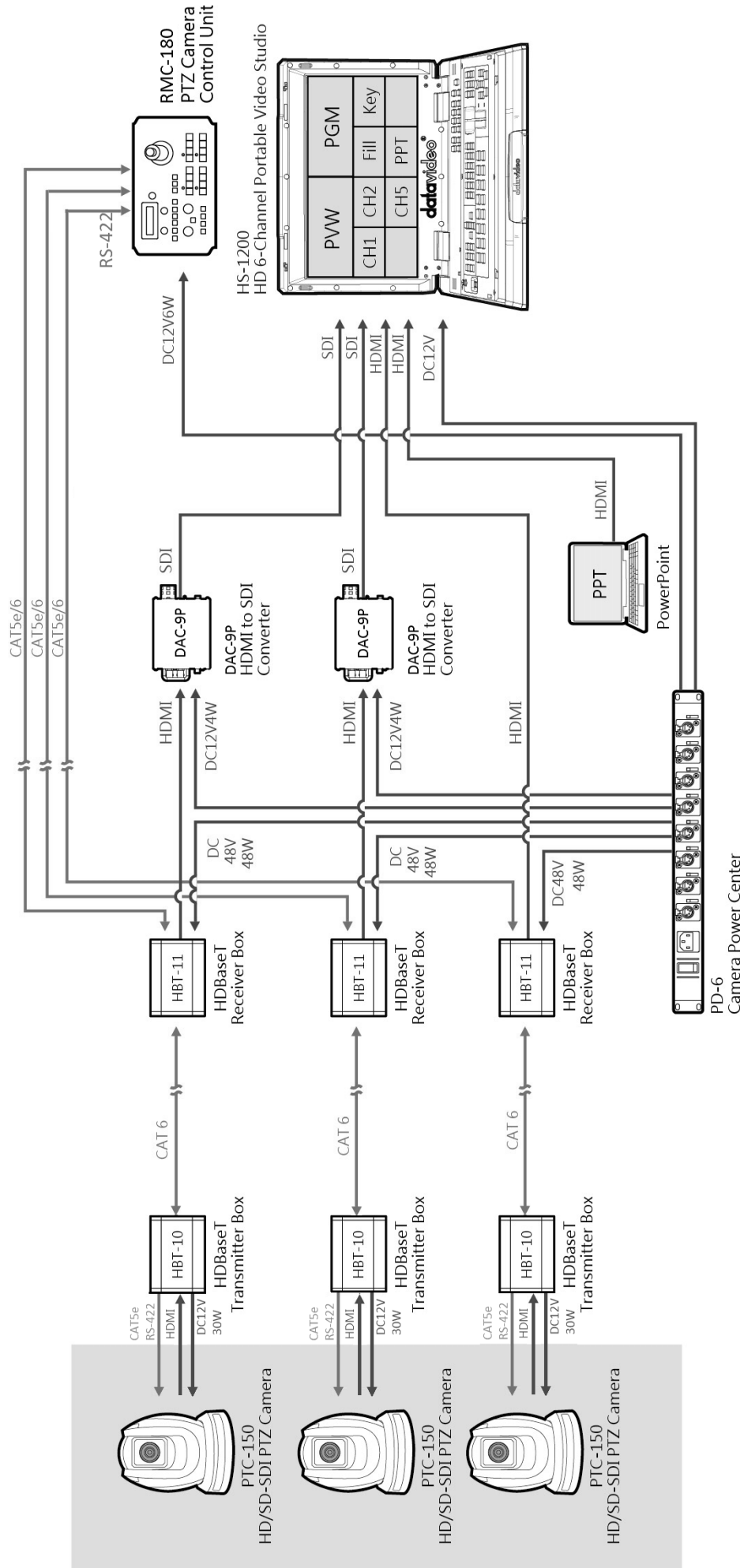

3. Connections

Rear Panel

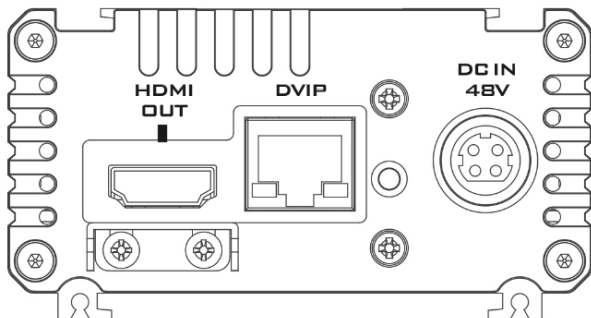

**HDMI
OUT**



HDMI OUT

HDMI port for video output.

DVIP



DVIP Port

Connects to Ethernet switch or router, serving as a communication port between the network and the HBT-11 receiver.

**DC IN
48V**



48V DC IN

48V DC power input connection



Power LED Indicator

ON: Power connected

OFF: Power disconnected

Front Panel

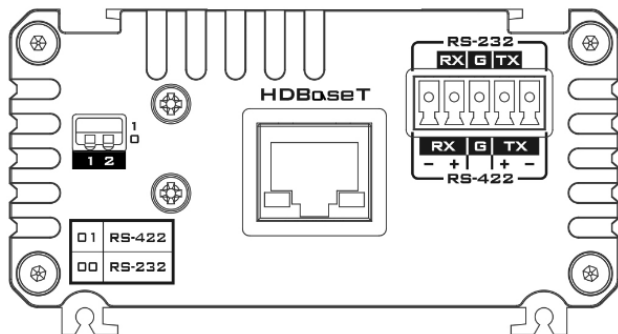

HDBaseT Port

Connects between HBT-10 transmitter and HBT-11 receiver.

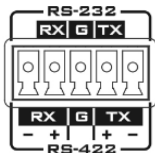

RS-232/RS-422 Interface (Phoenix Terminal)

Connects to external RS-232/RS-422 device.

RX: Receiver PIN (differential pair if RS-422 is enabled)

TX: Transmitter PIN (differential pair if RS-422 is enabled)

G: Ground PIN



DIP Switch

DIP Switch selects RS-232 or RS-422.

01: RS-422

00: RS-232

4. RS-422 Connection

To use the RMC-180 PTZ Camera Control Unit to control the PTZ-150 camera behind the HBT-11 Receiver box, please connect the RMC-180 to the HBT-11 by the RS-422 wiring scheme as shown below.

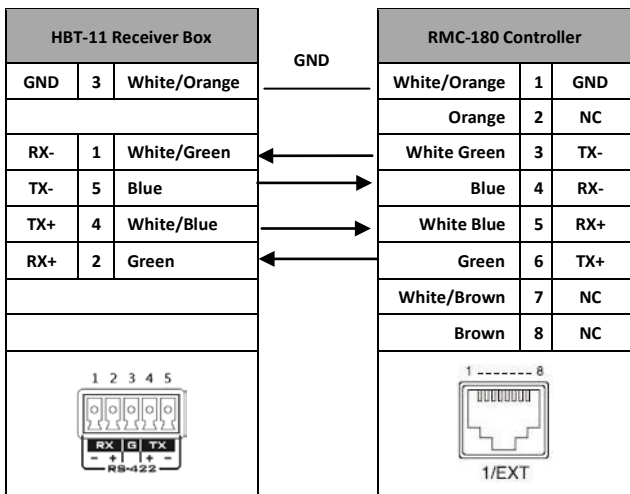

5. Dimensions

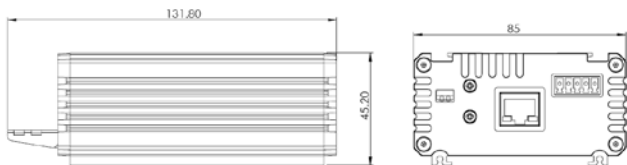

All measurements in millimeters (mm)

6. Specifications

Video / Audio	
Input	HDMI x 1
Output	HDBaseT RJ-45 x 1
Control	
DVIP Ethernet	RJ-45 x 1
RS-422 / RS-232	Phoenix Terminal Pitch 3.50 mm
Power	
DC IN	DC 48 V
Dimensions	
L x W x H	131.8 x 85 x 45.2 mm

Video Resolutions (HBT-10/HBT-11 Pair ONLY)			
Cable	Range		Video Resolution
CAT5e/6	100 meters		Up to 1080p, 60Hz, 36 bpp. Data rates lower than 5.3 Gbps or below 255 MHz TMDS clock.
	70 meters		Ultra HD video formats: HDMI Deep color: 1080p, 60, 48 bpp.
CAT6a/CAT7	100 meters(*)		4K x 2K Data rates higher than 5.3 Gbps or above 255 MHz TMDS clock.
* Recommended Cables for Ultra-HD video at 100 Meter range			
Type	P/N	Manufacturer	Web
CAT7 S/FTP	FR-LSZH	Teldor	http://www.teldor.com/
CAT6A H-STP	HFFR	Teldor	http://www.teldor.com/
CAT.7	2170475	Earthline	http://products.lappgroup.com/online-catalogue/datacommunication-systems-for-ethernet-technology/

Service & Support

It is our goal to make your products ownership a satisfying experience. Our supporting staff is available to assist you in setting up and operating your system. Please refer to our web site www.datavideo.com for answers to common questions, support requests or contact your local office below.

Datavideo Taiwan

Datavideo Technologies Co. Ltd
10F, No. 176, Jian 1st Rd., Chung Ho
District, New Taipei City 235, Taiwan,
R.O.C.
Tel: +886-2-8227-2888
Fax: +886-2-8227-2777
E-mail: service@datavideo.com.tw

Datavideo Europe

Datavideo Technologies Europe BV
Floridalaan 106
3565 AM Utrecht,
The Netherlands
Tel: +31-30-261-96-56
Fax: +31-30-261-96-57
E-mail: info@datavideo.nl

Datavideo United Kingdom

Datavideo UK Limited
Units1 & 2 Waterside Business Park
Hadfield, Glossop, Derbyshire
SK13 1SE, UK
Tel: +44-1457 851 000
Fax: +44-1457 850 964
E-mail: sales@datavideo.co.uk

Datavideo USA

Datavideo Corporation
7048 Elmer Avenue
Whittier, CA 90602,
U.S.A.
Tel: +1-562-996 2324
Fax: +1-562-688 6930
E-mail: sales@datavideo.us

Datavideo China

Datavideo Technologies China Co
101, NO. 618, LiuYing Rd, Zhabei District,
Shanghai, China
Tel: +86 21-5603 6599
Fax: +86 21-5603 6770
E-mail: service@datavideo.cn

Datavideo Singapore

Datavideo Technologies (S) PTE Ltd
No. 176 Paya Lebar Road #06-03
Singapore 409030
Tel: +65-6749 6866
Fax: +65-6749 3266
E-mail: sales@datavideo.sg

Datavideo Hong Kong

Datavideo Hong Kong Ltd
G/F, 26 Cross Lane
Wanchai, Hong Kong
Tel: +852-2633-1981
Fax: +852-2833-9916
E-mail: info@datavideo.com.hk

Datavideo France

Datavideo France s.a.r.l
Cit  Descartes 1, rue Albert Einstein
Champs sur Marne
774477-Marne la Vall e cedex 2
Tel: +33-1-00370240
E-mail: info@datavideo.fr

Datavideo India

Datavideo Technologies India Pvt L
A-132, Sec-63, Noida-201307,
Uttar Pradesh (UP), India.
Tel: +91-0120-2427337
Fax: +91-0120-2427338
E-mail: sales@datavideo.in



Please refer to our website for update the latest version manual.

www.datavideo.com/HDBaseT/HBT-11

datavideo

www.datavideo.com

All the trademarks are the properties of their respective owners.

Datavideo Technologies Co., Ltd. All rights reserved 2018

Aug-24,2016