

**datavideo**



Tracking PTZ Camera  
**PTC-145/ PTC-145T/ PTC-145NDI**

[www.datavideo.com](http://www.datavideo.com)

# Tracking PTZ Camera

The PTC-145 is a new auto-tracking PTZ head camera from Datavideo. The camera adopts a 1/2.8" CMOS sensor and 20x optical zoom, suitable for the auditorium, classroom, conference, and other applications. PTC-145 has an auto Tracking system function that presents smooth movement via the professional camera controller or remote controller, just like operated by a skilled videographer.

The 1/2.8-inch CMOS sensor provides high-quality images up to 1920X1080\_60P. The advanced digital noise reduction function gives you sharp images even in low light. The PTC-145 supports H.264 /H.265 video compression, dual streaming output, AAC, MP3, and G.711A audio compressions. Users can mix the audio via the web UI interface to meet live audio needs. In addition to DC power input, the PTC-145 supports PoE for easy installation.

Datavideo PTC-145T HDBaseT and PTC-145 NDI are also available to meet the needs of different users. So users can choose a proper model according to their actual needs.





## **PTC-145/ PTC-145T/ PTC-145NDI**

## **PTC-145W/ PTC-145TW/ PTC-145NDIW**

- Support auto tracking function
- 1/2.8" CMOS sensor
- Excellent low light performance (0.5 Lux@F1.8 AGC ON)
- 20X optical zoom, 8X digital zoom
- video output: HDMI, 3G-SDI, IP(H.264&H.265), HDBaseT (PTC-145T), NDI (PTC-145NDI)
- HDMI and SDI simultaneous video output
- Dual streaming to two different platforms
- Supports RS-422 series control, DVIP (DataVideo Proprietary Protocol) control and Sony VISCA Protocol
- PTC-145 series supports ONVIF Profile S standard
- External audio input: 3.5mm audio in
- Free download camera remote control App (iOS and Android)
- Powered by DC and POE
- User friendly web UI via browser.



**PTC-145/  
PTC-145T/  
PTC-145NDI**



# PTC-145



# PTC-145T

HDBaseT



# PTC-145NDI

NDI | HX3





### Quick Access to Camera's Auto Tracking

You have various camera controllers to turn on/off the auto tracking function of the camera, including the RMC-1AT remote controller, RMC-300A DVIP controller, PTC View Assist App, TPC-700, etc., you can choose a suitable controller according to your needs. In addition to the camera controller, you can quickly enable auto tracking with a video switcher that supports camera control functions, such as iCAST mini, KMU-200/300, or SHOWCAST 100.



### Custom Auto Object Tracking

If you are filming multiple people, you can designate a person for Auto tracking. Once linked to the camera, only the designated person will be tracked, avoiding interferences such as the desks, people coming back and forth, large objects, etc.



### Talent Position: Center / Left Side / Right Side

The positioning of talent depends on the videographer's creativity and intent rather than strict rules. Different positions can convey various emotions, messages, or visual effects. A centered composition provides a sense of stability and balance, suitable for scenes that require highlighting the main subject. Videographers may also place the talent on the left third or right third of the frame, leaving adequate space in the foreground to showcase the talent's sight direction or potential future possibilities.

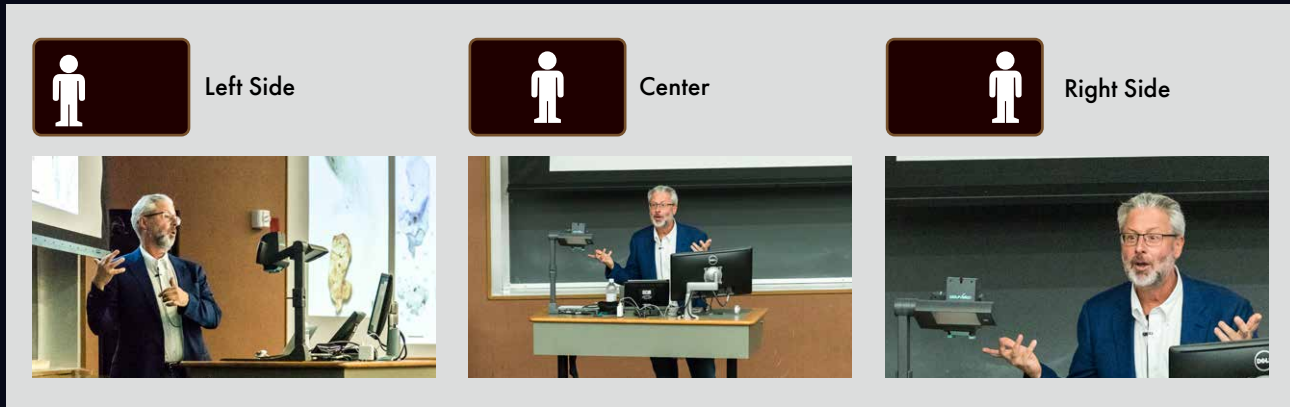

### Quick Access to Framing Options

All of the PTC-145 camera series include RMC-1AT controller. User can quickly select full-body, half-body and close up framing, making it easy to change the shooting scene and framing requirements.

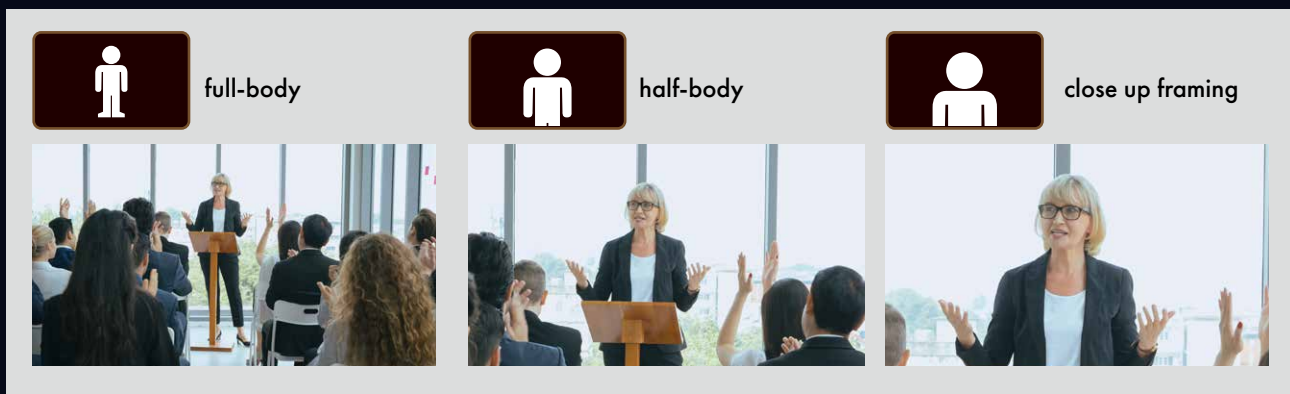

### Smart PTZ Speed Adaptation

The integrated PID algorithm is able to detect the movement speed of the identified object and automatically adjust the camera's corresponding pan, tilt and zoom speeds in such a way that the lens movement will be smooth, avoiding common camera lens movement problems like jerky movements or unpredicted halts.





### 20X Optical Zoom 8X Digital Zoom

The PTC-145's 20X optical zoom and 8X digital zoom allows you to mount it near or far and still get great, sharp shots.



Optical zoom



Digital zoom

### Broadcast Quality 1/2.8-inch CMOS Sensor

Resolution is up to 1920x1080 with a frame rate up to 60fps.

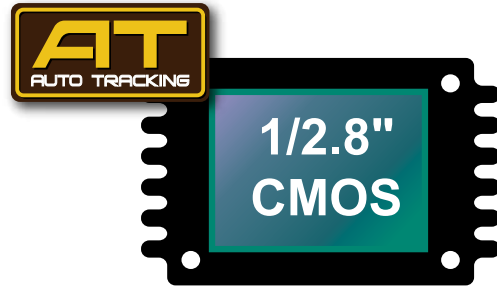

### Simultaneous Outputs

Connect your PTC-145 to multiple devices in your workflow for flexibility. All the outputs are active at the same time.



### Multiple Network Protocol with Dual Stream function

The PTC-145 series cameras support RTSP, RTMP(S), DHCP, TCP/IP, HTTP, and Multicast protocols, and all adhere to the ONVIF Profile S standard protocol. This ensures seamless integration and interoperability within network video systems. It is easy to stream directly to two different CDN platforms and Datavideo dvCloud.



### Various Control Options

Control real-time pan, tilt, and zoom camera movements with Datavideo SHOWCAST 100, iCAST mini switcher, PTZ View Assist APP, RMC-300A and RMC-180 camera controller series. With configurable preset positions supported.



SHOWCAST 100



PTZ View Assist app



iCAST mini



RMC-180 MARK II



RMC-300A

### Supports H.264/H.265 video compression

Support compression of resolution up to 3840x2160 with frame up to 59.94, 60fps and the second channel 1280x720p with 30fps compression. AAC, MP3 and PCM audio compression also supported.





## Low Noise in Low Light CMOS Effectively Ensures High SNR of Video Quality

Advanced 3D noise reduction technology is also used to further reduce the noise while ensuring image sharpness.



## Tally Light

Green and red tally lights to show the preview and program status for broadcast applications.



## Remote control and preview by web user interface

The web user interface provides preview, pan-tilt-zoom control and configurations setting in IP mode.

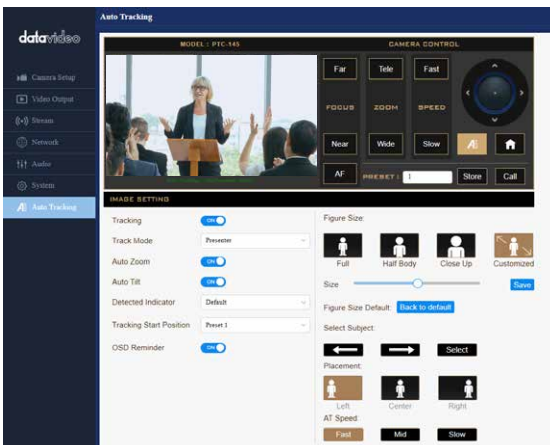

## RS-422, DVIP and Ethernet Camera Control

RS-422 and ethernet to use DVIP or VISCA over IP commands to integrate with larger control systems.



## Wide 60° Field of View

PTC-145 provides a wide field of view of 60°, easily shooting all the scenes in the field.

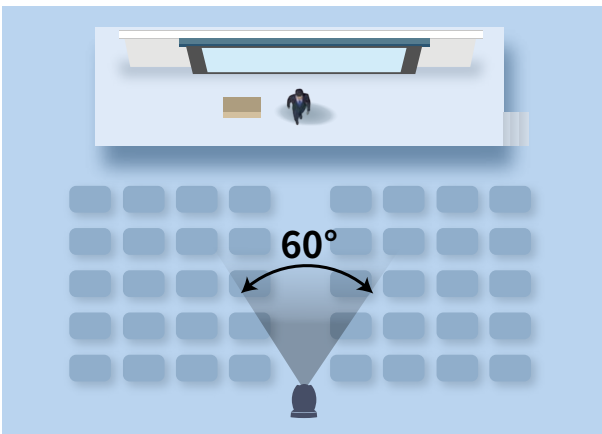

## Dark Blue and White Color Models

PTC-145 is available in two colors, dark blue and white. Suitable for broadcast, worship, video conferencing and etc.





Simply enable AI tracking  
with your IR remote control

RMC-1AT PTZ Controller



# All you need is a remote control to set and control all four cameras and save the four presets.

**Menu**  
Press the Menu button to open the camera's OSD menu which will show you all functions of the PTC-145.

**Power**  
Press to activate the camera or enter standby mode.

**Camera Selection / Setting**  
Select to set or control up to four cameras.

**Camera Presets**  
Each camera is allowed up to four presets which store the camera's current pan, tilt and zoom position, as well as settings such as iris, focus and movement speed. Presets allow quick access to settings required for specific camera shooting.

**Focus**  
Ergonomic design to ease manual focus adjustment.

**Zoom**  
Sets zoom speed and zooms in and out.

**Return**  
This returns the camera lens position to the Home position. When the OSD menu is opened, this button returns to the previous menu hierarchy level.

**Micro Joystick**  
The joystick controls the pan and tilt directions or selects options or values while the OSD menu is opened.

**IP Address Reset**  
Press and hold to restore the default IP address.

**AF Auto Focus**  
Press the AF button to turn on/ off auto focus function.

**Store**  
Saves the current pan, tilt and zoom settings of the camera as well as settings such as iris, focus and movement speed to presets 1 to 4.

**AT Tracking Enable**  
The AT button activates the auto tracking function of the PTC-145 series with one key. User can quickly select full-body, half-body and close up framing, making it easy to change the shooting scene and framing requirements.

**datavideo**  
RMC-1AT



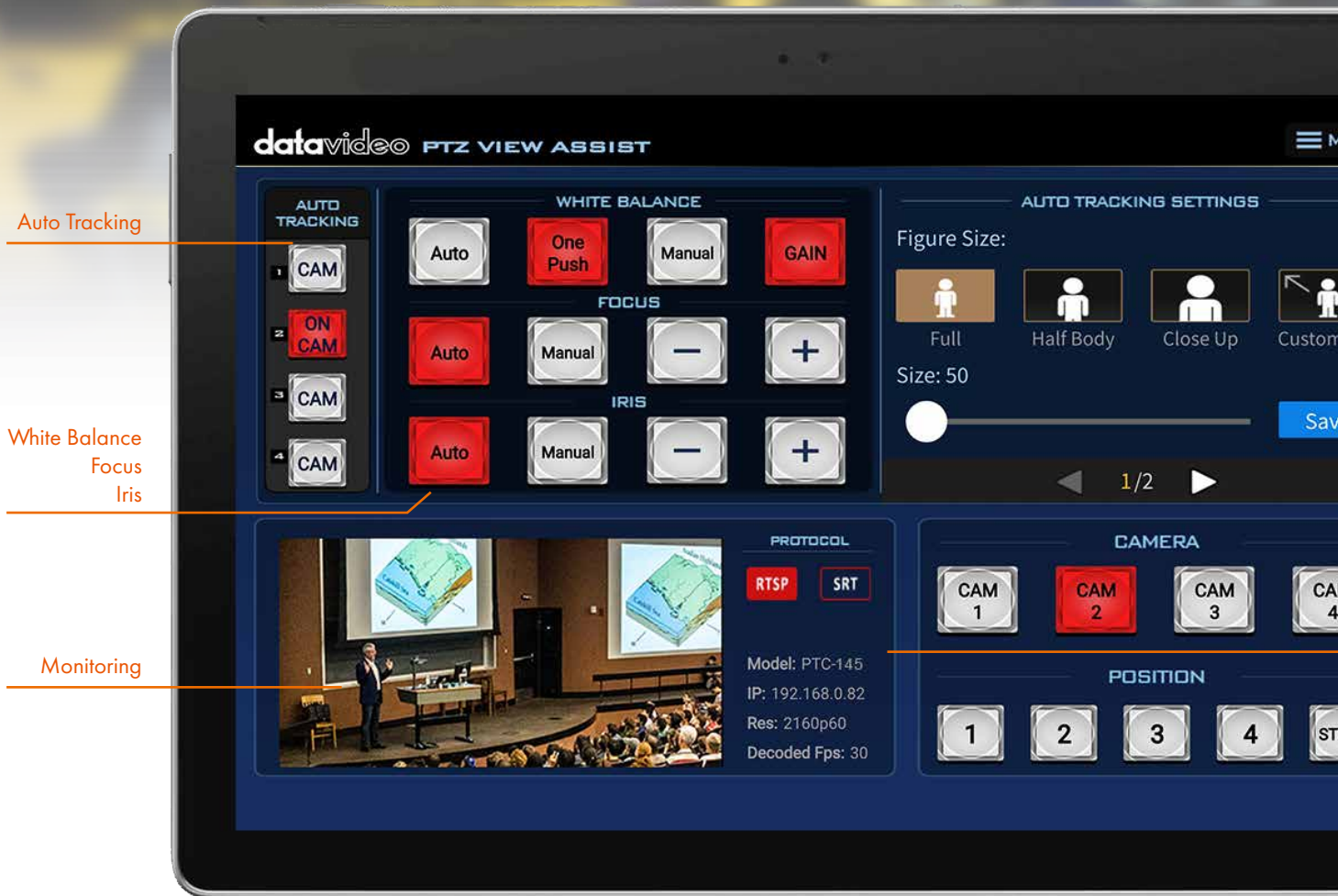

Auto Tracking

White Balance  
Focus  
Iris

Monitoring

# PTZ View Assist

## Control up to four cameras with your Tablet



The camera control app is tailored for the Datavideo PTZ camera series. It can monitor the live streaming video from PTC-140, PTC-145, PTC-280, PTC-285 and PTC-300 series. The app can control up to 4 cameras simultaneously via DVIP, you can intuitively set up and recall the presets, and adjust white balance, focus, and IRIS. The app can decode the live streaming via RTSP (SRT and NDI steaming coming soon), easily monitor the live streaming video and set up the parameters promptly in one application. Datavideo provides iOS and Android versions, you can download on Google Play and App Store for free!





Mobile phone version available soon

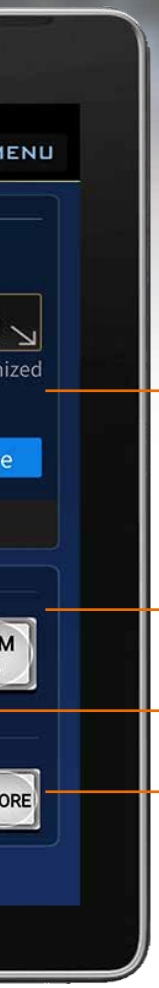

Auto Tracking Setting

Camera

Protocol

Preset Position



### Camera control via web UI APP control

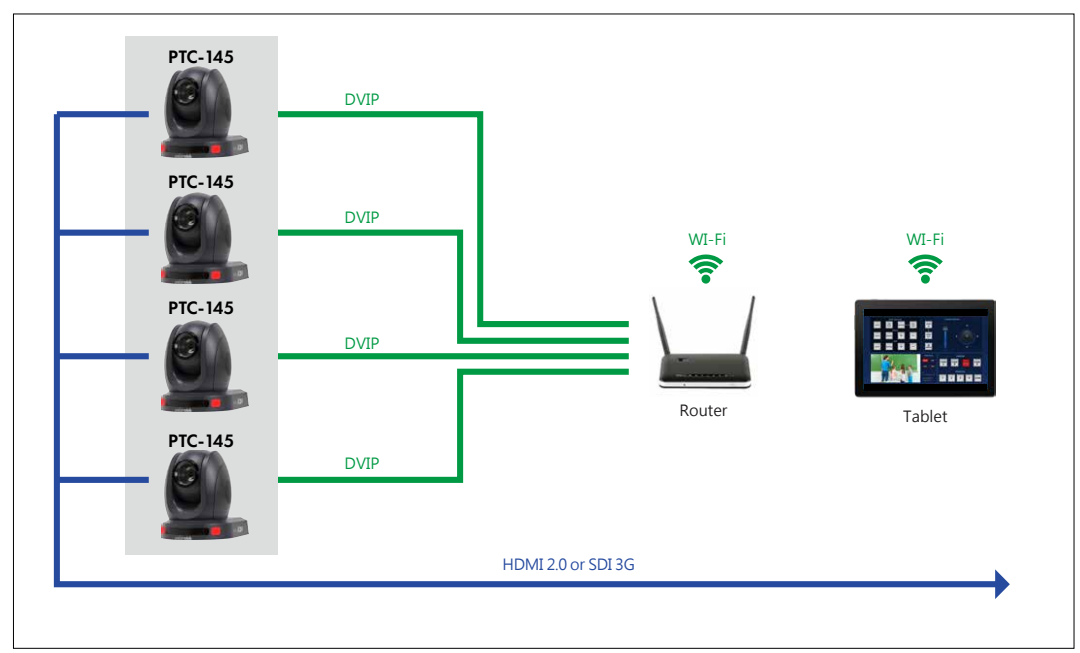

The camera control app is able to control datavideo PTZ cameras. Once you install the app on the tablet, it is easy to control the cameras in the same network!

## PTC-145

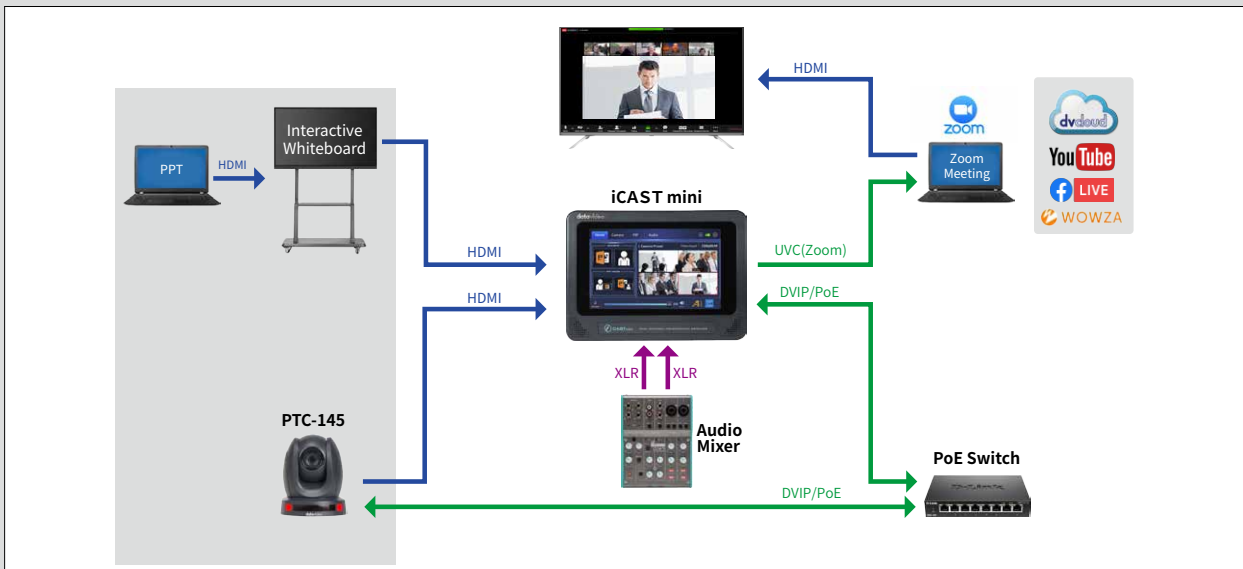

## PTC-145T

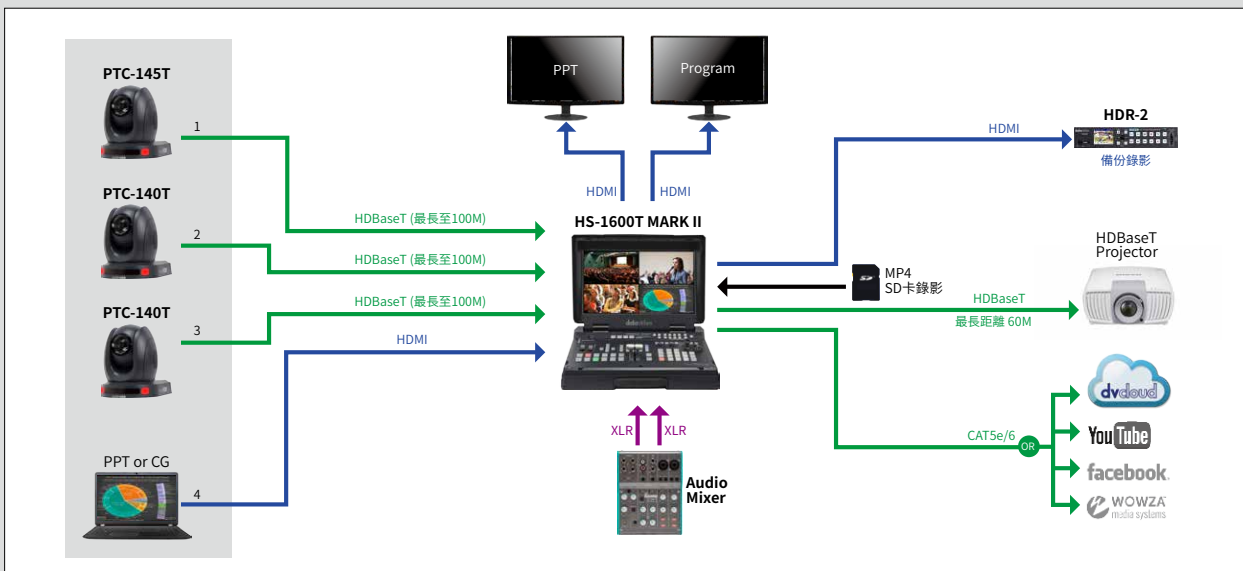

## PTC-145NDI

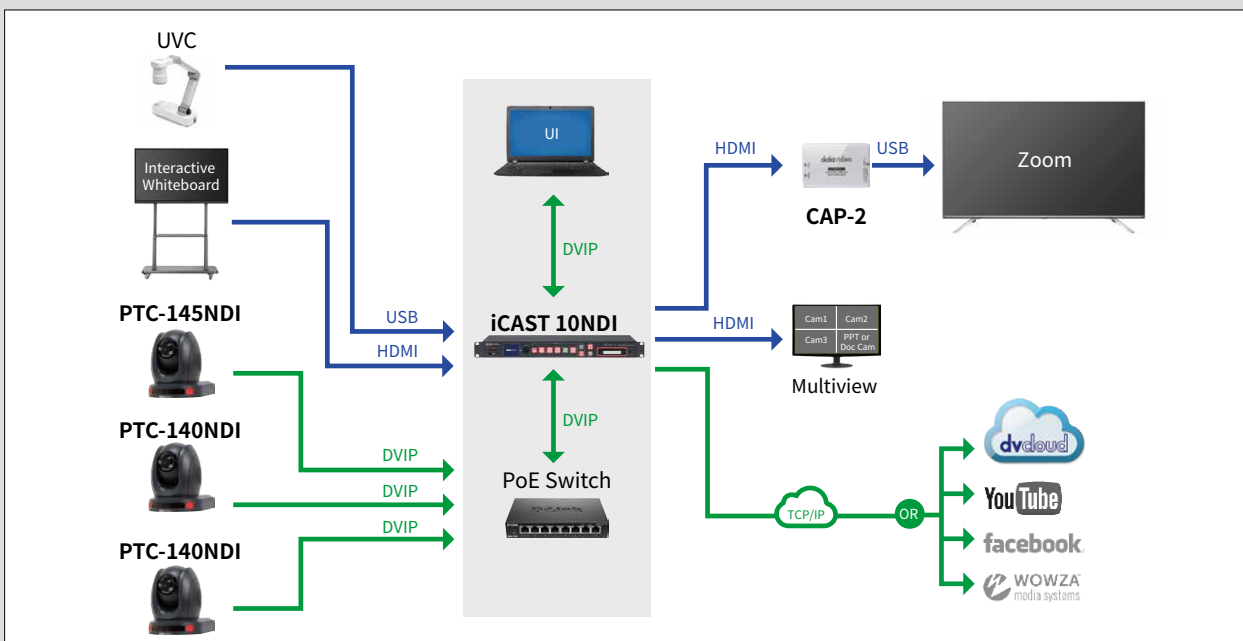

## Optional accessories



**VP-929**  
HDMI 4K Repeater

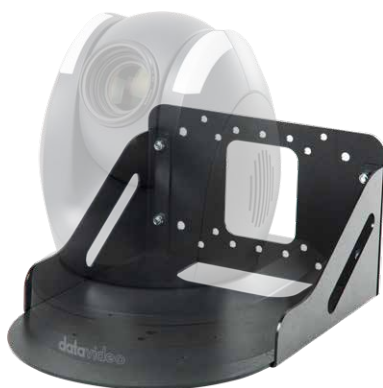

**WM-1**  
Wall Mount



**WM-1W**  
Wall Mount (White)

The WM-1 can be positioned upside-down or rightside-up to suit various applications. The three-piece design is sturdy, and easy to install onto any wall.

## What's in the box accessories



**RMC-1AT**  
IR remote control



Ceiling mount bracket



DC 12V Adaptor

## Dimension

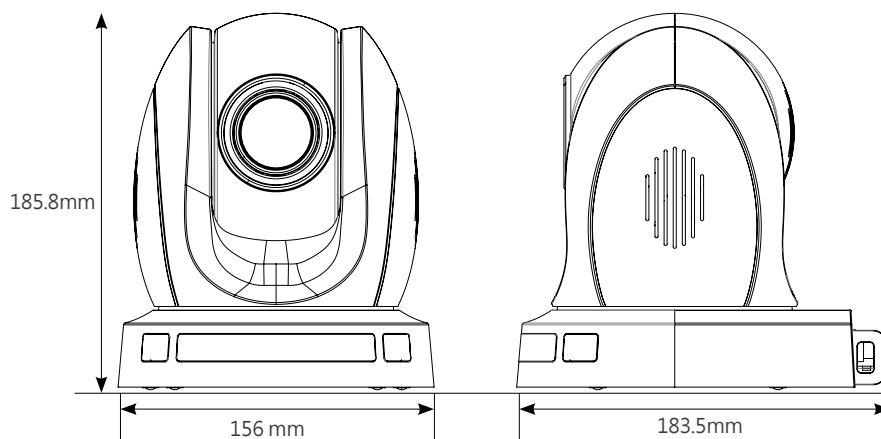

# Specification



	PTC-145	PTC-145T	PTC-145NDI
Product Name	HD Tracking PTZ Camera	HD HDBaset Tracking PTZ Camera	HD NDI Tracking PTZ Camera
Video format/Resolution	1080p 60/59.94/50/30/29.97/25 1080i 60/59.94/50 720p 60/59.94/50	1080p 60/59.94/50/30/29.97/25 1080i 60/59.94/50 720p 60/59.94/50	1080p 60/59.94/50/30/29.97/25 1080i 60/59.94/50 720p 60/59.94/50
Image Sensor	1/2.8 inch high quality HD CMOS sensor	1/2.8 inch high quality HD CMOS sensor	1/2.8 inch high quality HD CMOS sensor
Effective Pixels (approx.)	2.07 Mega pixels	2.07 Mega pixels	2.07 Mega pixels
S/N Ratio	50dB	>55dB	>55dB
Min. Illumination	0.5Lux (F1.8, AGC ON)	0.5Lux (F1.8, AGC ON)	0.5Lux (F1.8, AGC ON)
Electronic Shutter	1/30s ~ 1/10000s	Auto / Manual	Auto / Manual
Zoom Ratio	20x Optical Zoom, 8x Digital Zoom	20x Optical Zoom, 8x Digital Zoom	20x Optical Zoom, 8x Digital Zoom
Gamma Control	Off / Normal	Off / Normal	Off / Normal
Iris Control	Auto / Manual	Auto / Manual	Auto / Manual
Digital Noise Reductions	3D	3D	3D
On-Screen Display (OSD)	English, Simplified Chinese	English/Simplified Chinese/Traditional Chinese	English/Simplified Chinese/Traditional Chinese
White Balance	Auto, Indoor, Outdoor, Manual, One Push,	Auto, Indoor, Outdoor, Manual, One Push	Auto, Indoor, Outdoor, Manual, One Push
AGC / Gain Control	Yes	Auto / Manual	Auto / Manual
Mirror / Flip Image	Yes	Yes	Yes
Focus Mode	Auto / Manual	Auto / Manual	Auto / Manual
Panning / Tilting Range	Pan: 340° , Tilt: +90° to -30°	Pan: 340° , Tilt: +90° to -30°	Pan: 340° , Tilt: +90° to -30°
Panning / Tilting Speed	Pan: 0.1~60°/sec Tilt: 0.1~30°/sec	Pan: 0.1~60°/sec Tilt: 0.1~30°/sec	Pan: 0.1~60°/sec Tilt: 0.1~30°/sec
Preset	255 Position	255 Position	255 Position
Focal Length	f = 5.05mm (wide) to 91.49 mm (tele) F1.8(Wide) ~ F2.9(Tele)	f = 5.05mm (wide) to 91.49 mm (tele) F1.8(Wide) ~ F2.9(Tele)	f = 5.05mm (wide) to 91.49 mm (tele) F1.8(Wide) ~ F2.9(Tele)
Field of View (Horizontal, Wide)	Approx. 60° (WIDE END)	Approx. 60° (WIDE END)	Approx. 60° (WIDE END)
Image Compensation	Backlight Compensation	Backlight Compensation	Backlight Compensation
Video Output	HDMI x 1 SDI x 1 RJ-45 PoE x 1	HDBaset (PoE) x1 RJ-45 x 1	HDMI x1 SDI x1 RJ-45 PoE x1
Audio Input	3.5mm Line in	3.5mm Line in	3.5mm Line in
Tally LED	Dual color (Red, Green)	Dual color (Red, Green)	Dual color (Red, Green)
Lens Filter	M52.0 x 0.75 Thread with UV Protection	M52.0 x 0.75 Thread with UV Protection	M52.0 x 0.75 Thread with UV Protection
Control Protocol	Pelco-D, Pelco-P, VISCA, VISCA over IP DHCP, RTSP, RTMP (IP Cam), RTMPS, DVIP, ONVIF, SRT	Pelco-D, Pelco-P, VISCA, VISCA over IP DHCP, RTSP, RTMP (IP Cam), RTMPS, DVIP, ONVIF, SRT	Pelco-D, Pelco-P, VISCA, VISCA over IP DHCP, RTSP, RTMP (IP Cam), RTMPS, DVIP, ONVIF, SRT NDI
Remote Control Interface	RJ-45: for IP control (DVIP) RS-232/RS-422/RS-485	RS-232 Lan (RJ-45) HDBaset(RJ-45)/Serial control on Receiver Box: Transmit up to 100m	LAN: for IP control (DVIP / NDI) RS-232, RS-422, RS-485
Video Compression Format	H.264, H.265, Dual stream output	H.264, H.265, Dual stream output	H.264, H.265, Dual stream output
Audio Compression Format	AAC/MP3/G.711A Audio compression	AAC/MP3/G.711A Audio compression	AAC/MP3/G.711A Audio compression
Audio Bitrate	96Kbps, 128Kbps, 256Kbps	96Kbps, 128Kbps, 256Kbps	96Kbps, 128Kbps, 256Kbps
HD IP Interface	100M IP port(100BASE-TX); Support DVIP	100M IP port(100BASE-TX); Support DVIP	100M IP port(100BASE-TX); Support DVIP and NDI
Streaming Protocols	RTSP, RTMP(S), ONVIF, SRT(caller & listener), Multicast	RTSP, RTMP(S), ONVIF, SRT(caller & listener), Multicast	RTSP, RTMP(S), ONVIF, SRT(caller & listener), Multicast, NDI   Hx3
First Stream Supported Resolution	1920x1080 1280x720 1024x576 960x540 640x480 640x360	1920x1080 1280x720 1024x576 960x540 640x480 640x360	1920x1080 1280x720 1024x576 960x540 640x480 640x360
Second Stream Supported Resolution	720x480 640x360 480x270 320x240	720x480 640x360 480x270 320x240	720x480 640x360 480x270 320x240
Video Bitrate	32Kbps ~ 50Mbps (Single Stream)	32Kbps ~ 50Mbps (Single Stream)	32Kbps ~ 50Mbps (Single Stream)
Video Bitrate Mode	VBR, CBR	VBR, CBR	VBR, CBR
Encoding Frame rate	50Hz: 1-50fps 60Hz: 1-60fps	50Hz: 1-50fps 60Hz: 1-60fps	50Hz: 1-50fps 60Hz: 1-60fps
POE	IEEE 802.3af	IEEE 802.3af	IEEE 802.3af
F/W Update	Ethernet	Ethernet	Ethernet
IR Control	Yes	Yes	Yes
Camera Control Unit	RMC-180 series/RMC-300 series/ PTZ View Assist APP	HS-1500T/HS-1600T series/RMC-180 series/RMC- 300 series/PTZ View Assist APP	RMC-180 series/RMC-300 series/PTZ View Assist APP
Tripod Mount	1/4-20 UNC	1/4-20 UNC	1/4-20 UNC
Optional Accessories	WM-1/ WM-10/ WM-11	WM-1/ WM-10/ WM-11	WM-1/ WM-10/ WM-11
Color	Dark Blue/White	Dark Blue/White	Dark Blue/White
Dimension (LxWxH)	156 x 184 x 186 mm	156 x 184 x 186 mm	156 x 184 x 186 mm
Weight	1.6 kg	1.6 kg	1.6 kg
Operating Temp. Range	0~40 °C	0~40 °C	0~40 °C
Power	DC 12V 12W	DC 12V 12W	DC 12V 12W



@DatavideoUSA  
@DatavideoEMEA  
@DatavideoTaiwan

@DatavideoAsia  
@DatavideoIndia2016  
@Datavideojapan



@Datavideo  
@Datavideo\_EMEA  
@Datavideo\_Taiwan



@DatavideoUSA  
@DVTWVVCN



@DatavideoUSA  
@DatavideoEurope

## Disclaimers of Product and Services

This brochure is intended as a guide only. We reserve the right to change specifications and availability without prior notice. While we strive for complete accuracy, be aware that it may contain errors and omissions. Prior to purchase, please check with your local Datavideo office or authorised distributor.