

datavideo



# Pro Audio Delay Box

**AD-300**

[www.datavideo.com](http://www.datavideo.com)

# AD-300

## Pro Audio Delay Box

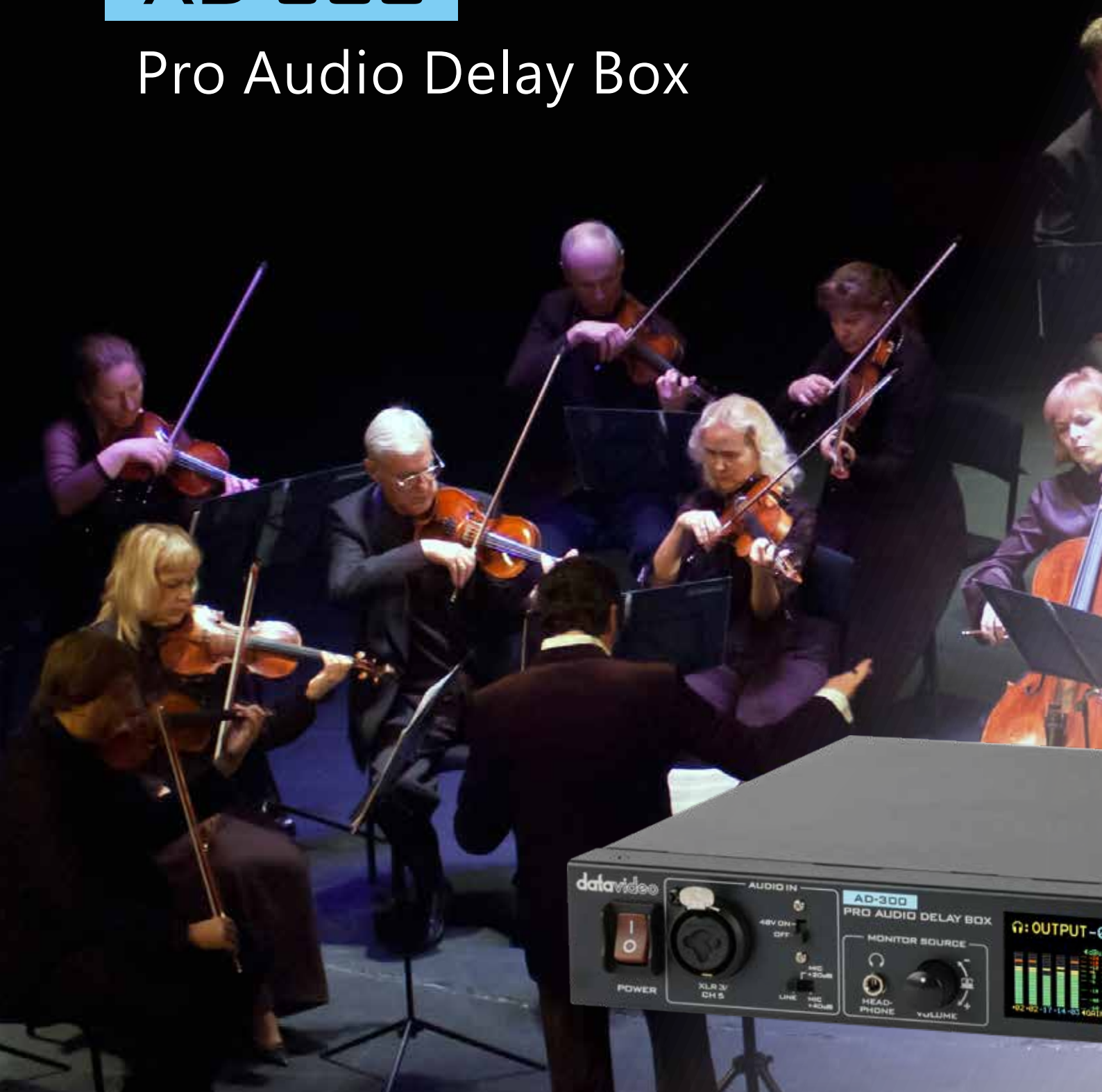

A Pro Audio Delay Box with audio mixing, equalization, filtering and dynamics effects

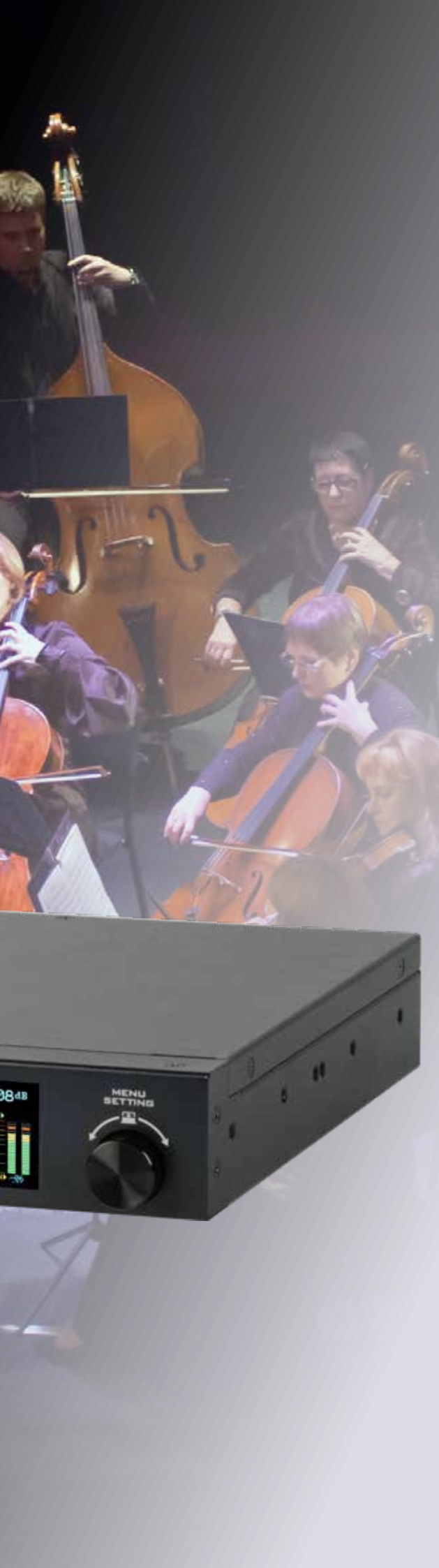

The new AD-300 professional audio delay box is equipped with 5 input channels and 2 output channels as well as the capability of processing multiple audio inputs for your live production. With the AD-300, you will be able to delay the audio input for up to 3,000 ms, mix multiple audio inputs in different combinations and apply various audio dynamics effects such as audio equalization and filtering, etc. You can also fine tune each audio input individually to gain a professional audio experience and precise audio/video synchronization. Moreover, the equalizer allows you to customize the audio effect by adjusting the audio volume ( $\pm 10$  dB) of up to eight frequency bands ranging from 125 Hz to 16 KHz.

The 2 inch LCD screen on the front panel gives you access to all of the functions that the AD-300 provides. Compressors and limiters adjust the volume of the audio inputs with a maximum compression ratio of 100:1 in the compressor. Expanders and gates make certain instrument and human voice sound more prominent with also a maximum attenuation ratio of 100:1 in the expander. The built-in balanced and unbalanced audio conversion ensures that the audio output is always in the right format. The Line/MIC switch allows you to switch between microphone and line inputs. In addition, the 48V phantom power is included to power connected condenser microphones. These powerful features are housed in a compact case, ideal for standalone and rackmount applications.

- Adequate input and output channels: three XLR balanced and two RCA unbalanced inputs and one XLR and RCA output.
- The front and rear panels are equipped with an XLR input channel and a +48V phantom power switch making system setup easy and flexible.
- Professional audio delay of up to 3000 msec with individual channel configuration and precise audio/video synchronization.
- A built-in five channel mixer.
- 8 independent frequency bands in each equalizer.
- Unique audio dynamics effects such as Compressor, Limiter, Expander and Gate.
- Highpass and lowpass audio filters to eliminate high frequency interference or retain specific audio components.
- Built-in balanced/unbalanced audio conversion.

## Front Panel



### 48V phantom power switch

The 48V phantom power is designed for powering condenser microphones.

### Fifth audio channel input

The XLR balanced / 1/4" (6.3mm) port connects an audio device or a condenser/dynamic microphone.

### Input switch

There are three input modes which are LINE IN and MIC inputs with either a 20 dB or 40 dB preamplifier.

### Headphone jack/volume control knob

Monitor five audio inputs and two audio outputs with the headset. Press the knob to switch audio channels and rotate the knob to adjust the volume.

## Rear Panel



### F/W Update Interface

### Audio channel output port

The XLR unbalanced and RCA balanced stereo channels deliver processed or delayed audio signals.

### First and second audio channel inputs

Two RCA unbalanced audio channel inputs can conveniently connect to cell phones, computers, etc.

## Adequate input and output channels with the front and rear panels equipped with an XLR input channel and a +48V phantom power switch

The AD-300 is equipped with a variety of input and output channels for live video production. The three XLR balanced and two RCA unbalanced stereo inputs can connect different audio sources such as computers, cellphones, microphones, etc. There are also XLR and RCA audio output channels.



### 2" LCD screen

A well-designed easy-to-use menu that displays all options and parameters on the 2" LCD screen.

### Easy-to-use menu knob

Rotate the round easy-to-use menu knob to navigate the menu and press to select an option. You can practically access all functions with a single knob.



### Third and fourth audio channel inputs

The XLR balanced / 1/4" (6.3mm) sockets can connect audio sources or condenser/dynamic microphones and are also equipped with an input switch and a 48V phantom power switch.

### 48V phantom power switch

The AD-300 powers condenser microphones with a 48V phantom power supply.

## Professional and precise audio/video synchronization

The AD-300 pro audio delay box is able to delay the audio for up to 3000 ms. Each audio channel input can be delayed individually in milliseconds for professional and precise audio/video synchronization.



The audio channel inputs can be delayed individually

RCA-L 70mSEC

RCA-R 70mSEC

XLR-1 80mSEC

XLR-2 80mSEC

XLR-3 70mSEC

## Audio Processing:

### Compressor

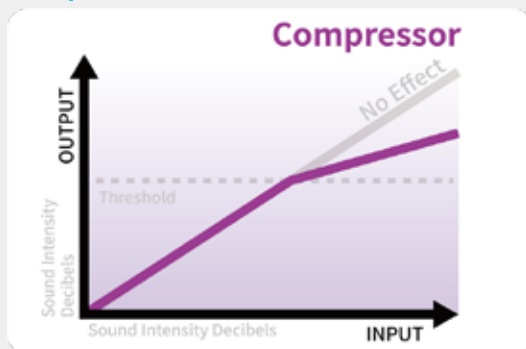

A compressor reduces the level of loud sections of the audio signal while leaving lower levels unchanged, thereby reducing the dynamic range. The compressor has a maximum compression ratio of 100:1 and an ideal attack time can be set to 50 - 500 msec which is basically the time required to complete the audio compression.

### Limiter

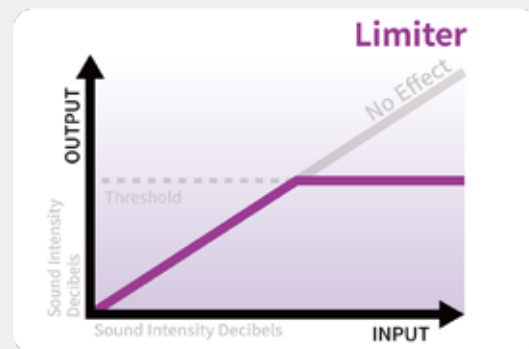

A limiter limits the audio signal to a certain threshold and is often activated in conjunction with the compressor. It basically sets the maximum audio volume and is applied at audio mastering. The threshold range is +24dBu to -6dBu. The attack time can be selected from 50~500ms.

### Expander

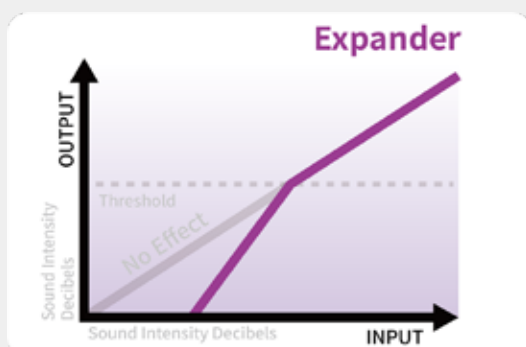

The Expander is exactly the opposite of the Compressor and is used to extend the audio dynamic range by diminishing the quiet components so that the loud components are more prominent. The expander makes changes in instrument and human sounds more obvious.

### Gate

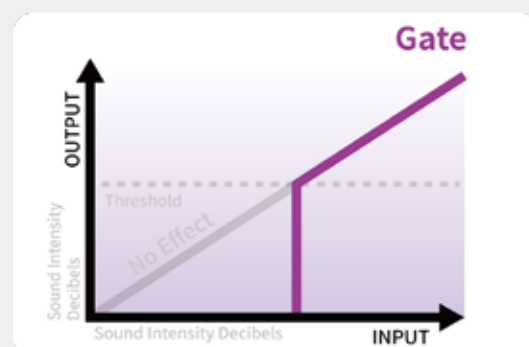

If the audio volume falls below the threshold, the Gate will eliminate that particular audio component. The Gate is primarily used to remove unwanted audio. The configurable range of the Gate Threshold is between -66 dBu and -25 dBu.

### Built-in mixer

The AD-300 is not only an audio delay unit but also an audio mixer, allowing you to mix five audio input channels in different combinations and deliver the mixed audio to two audio output channels.

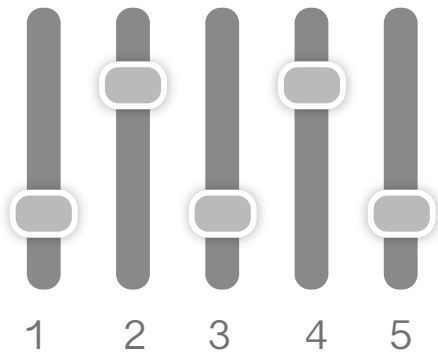

### Equalizers refine audio quality

The AD-300's equalizer allows you to eliminate or mitigate the strength of unwanted audio components or make a particular frequency band more prominent. Within the 125 Hz to 16 KHz range, there are eight frequency bands with each band having an allowable signal strength range of  $\pm 10$  dB. All audio input channels are independent from one another so each channel can be adjusted individually for a custom audio effect.

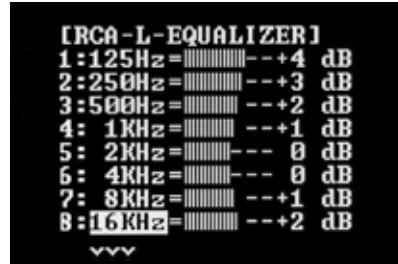

### Audio filter cascade

In addition to the basic highpass and lowpass filters, the AD-300 is also capable of cascading the two filters in either the highpass and lowpass combination or the lowpass and highpass combination. This can serve to eliminate high frequency noises or passes a custom audio frequency band.

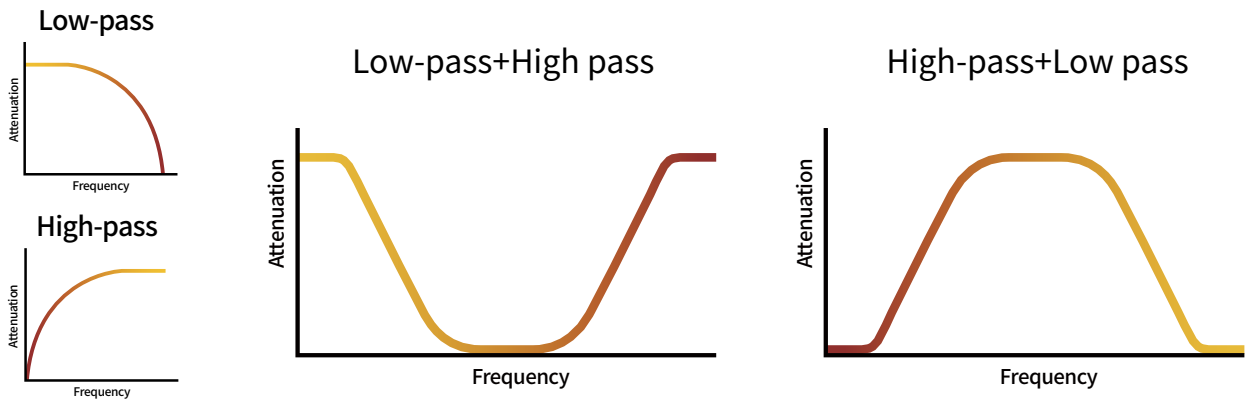

### Balanced/Unbalanced Audio Conversion With the built-in balanced/unbalanced

audio conversion function, audio defects or low volume can be avoided under normal circumstances. The balanced/unbalanced audio conversion ensures that the audio output is always in the right format.

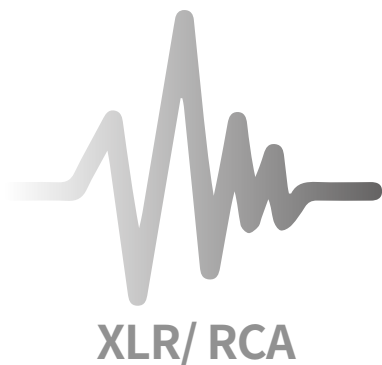

### Mic in with +48V phantom power

The AD-300 offers MIC and Line inputs and supports +48V phantom power for condenser microphones. The MIC IN is equipped with 20 and 40 dB preamplifiers which amplify weak MIC signals for digital signal processing.



## Related Products



**AD-100**  
Audio Delay Box

- Easy to use design
- Audio delay ranging from 0 to 400 ms
- External USB power supply
- Full range of input settings to satisfy a variety of applications.
- Highly compatible outputs



**AM-100**  
Rackmount Audio Mixer

- Audio volume indicators
- Supports A+V function so that the MIC sound is synchronized with the video.
- Supports XLR microphone input and +48V phantom power.



**AD-200**  
6-Channel Audio Delay/Mixer  
with Level Adjustment

- A 2-in-1 device: audio mixer and delayer
- Supports up to 3 sec audio delay for each audio input channel
- 6 audio input channels which can be matrix mapped onto 4 audio output channels.
- Audio input channels with adjustable volumes.

## Optional Accessories



**RMK-1**  
1U Rackmount Kit

The RMK-1 is a rack mounting accessory for Datavideo 0.5U sized products. The RMK-1 can mount one or two AD-300 products into a 1U rack space.

## System Diagram

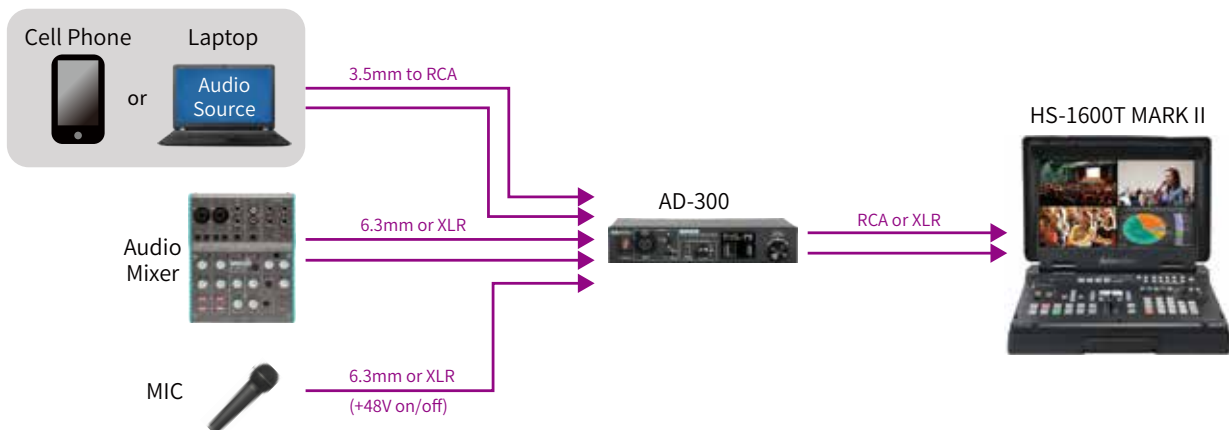



# System Diagram

Interfaces		
Audio Input	3 x balanced stereo audio / Microphone (3 Pin XLR / 1/4" (6.3mm) Socket) 2 x unbalanced stereo audio, RCA sockets	
Audio Output	2 x balanced stereo audio, XLR connectors 2 x unbalanced stereo audio, RCA sockets	
Headphone	1 x 3.5mm Stereo headphone (with volume control)	
Display	2" LCD	
MIC Gain / LINE Switch	MIC phantom power: 48V (ON / OFF) MIC+40dB/ MIC+20dB/ LINE	
Firmware Update	Mini USB	
Power	DC In 12V	
Audio Specification		
Audio Delay	Up to 3000ms	
Output Max Level	+24dBu	
	Bandwidth	20Hz~20KHz < +/- 3dB
	S/N Ratio	> 80 dB @1KHz, 14dBu (signal level)
	T.H.D.	< 0.01% @1KHz,14dBu
	Isolation	> 75dB
Line Input (RCA)	Bandwidth	20Hz~20KHz < +/- 3dB
	S/N Ratio	> 80 dB @1KHz,0dBV (signal level)
	T.H.D.	< 0.01% @1KHz,0dBV
	Isolation	> 75dB
Microphone Input (XLR)	Bandwidth	20Hz~20KHz < +/- 3dB
	S/N Ratio	> 75 dB @1KHz, +20dB gain > 70 dB @1KHz, +40dB gain
	T.H.D.	< 0.03% @1KHz, +20dB gain < 0.5% @1KHz, +40dB gain
	Isolation	> 75dB @+20dB gain > 70dB @+40dB gain
Audio Processors		
Compressor	Yes	
Limitter	Yes	
Gate	Yes	
Expander	Yes	
Equalizer	Yes	
Filter	Yes	
Delay	Yes	
General		
Operating Temperature	0° C to 40° C (32° F to 104° F)	
Storage Temperature	-20° C to 60° C (-4° F to 140° F)	
Humidity	10% to 80% (non-condensing)	
Dimension (mm)	205mm (W) x 235mm (D) x 45mm (H)	
Weight	1.3 Kg	



@DatavideoUSA @DatavideoAsia  
@DatavideoEMEA @DatavideoIndia2016  
@DatavideoTaiwan @Datavideojapan



@Datavideo  
@Datavideo\_EMEA  
@Datavideo\_Taiwan



@DatavideoUSA  
@DVTWDVCN



@DatavideoUSA  
@DatavideoEurope

---

#### Disclaimers of Product and Services

This brochure is intended as a guide only. We reserve the right to change specifications and availability without prior notice. While we strive for complete accuracy, be aware that it may contain errors and omissions. Prior to purchase, please check with your local Datavideo office or authorised distributor.

Ver.20220105